

GB 1542847  
MAR 1979

CURR/ ★ Q67 C7688B/13 ★ GB 1542-847  
Fluid-tight pipe coupling - has soft outer connecting sleeve fitting over pipe and reduced thickness region allowing inward deformation to grip pipe

CURRANTE 29.04.75-GB-017678  
(28.03.79) E161-13/14

The pipe coupling has two tubular elements in the form of a tubular coupling sleeve (10) and a pipe (11).

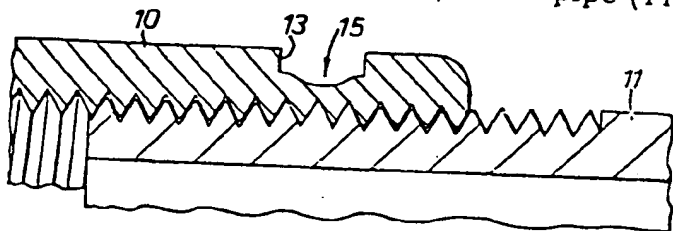

The sleeve is of a suitable size to fit over the pipe. The wall of the outer of the two tubular elements

(10) has a peripheral annular region (13) of reduced thickness and the element is made of a softer material than the inner (11).

A positive grip to lock the coupling together is achieved by inwardly deforming (15) the region of the outer element.  
26.4.76 (6pp1396)

## PATENT SPECIFICATION

(11) 1 542 847

1 542 847

(21) Application No. 17678/75 (22) Filed 29 April 1975

(23) Complete Specification filed 26 April 1976

(44) Complete Specification published 28 March 1979

(51) INT. CL.<sup>2</sup> F16L 13/14(52) Index at acceptance  
F2G 24C 25A

## (54) IMPROVEMENTS IN OR RELATING TO PIPE COUPLINGS

(71) I, THOMAS EUGENE CURRAN of 9, Tyrwhitt Crescent, Roath Park, Cardiff, Glamorgan, a British subject, do hereby declare the invention, for which I pray that a patent may be granted to me, and the method by which it is to be performed to be particularly described in and by the following statement:—

This invention relates to pipe couplings for use in connecting fluid transmitting pipes such as fuel lines, or lines conveying steam, compressed air, gases etc. In such couplings it is important that the joints between the pipes should be fluid or gas-tight at appreciable pressures and since the fuel or other fluid may be inflammable, the coupling should avoid the need for welding operations or the like and must preferably eliminate organic packing materials which might be affected by the fuel; it is also desirable that the coupling should be economical to manufacture and assemble.

Broadly stated in one aspect the invention consists in a pipe coupling combination comprising two tubular elements in the form of a tubular coupling sleeve and a pipe, the sleeve being dimensioned to be placed in or over the end of the pipe, the wall of the outer of the two tubular elements in the coupled assembly being of reduced thickness in an annular region around its periphery, and constructed of a material softer than that of the inner tubular element, such that the wall in the annular region can be deformed inwardly to provide a positive grip between the elements.

Preferably the inward deformation of the annular region also provides a seal between the elements.

The invention also consists in a method of assembling a pipe coupling joint in which one of the tubular elements of the pipe coupling combination, is placed in or over the end of the other tubular element and the wall of the outer tubular element is de-

formed inwardly to provide a positive grip between the tubular elements. Preferably the outer tubular element is deformed by means of a rotary tool provided with a number of spaced rollers, means for pressing the rollers inwardly against the tubular element and means for rotating the rollers bodily around the axis of the tubular element.

The invention may be performed in various ways and one specific embodiment, with some possible modifications, will now be described by way of example with reference to the accompanying drawings, in which:

Figure 1 is a sectional side elevation through a coupling according to the invention, with two pipe ends located in the coupling, before the final contracting operation,

Figure 2 is a partial sectional elevation on an enlarged scale illustrating the final contraction of the sleeve wall at one end,

Figure 3 is a perspective view of a modified pipe cutter as used for this contraction process,

Figure 4 is a perspective view of one of the rollers which are substituted for the conventional cutter wheels,

Figure 5 is a sectional elevation on an enlarged scale illustrating an alternative form of coupling sleeve according to the invention,

Figures 6 and 7 are further sectional side elevations illustrating further alternatives,

Figure 8 is a sectional side elevation through another form of pipe coupling according to the invention with two pipe ends, before the final contracting operation, and

Figure 9 is a side elevation illustrating the final form of the joint provided by the coupling of Figure 8.

Referring first to Figures 1 and 2, the coupling comprises a cylindrical sleeve

60

65

75

80

85

90

of steel or malleable iron or other malleable material formed with an internal screw thread to receive the screw-threaded ends of two pipe sections 11, 12. The ends of these two pipes are preferably slightly tapered at the screw-thread portion to assist in forming a tight seal at the joint. Such couplings are well known, but in practice it is found that even when using packing materials leaks occur, particularly at high pressures, and when the fluid line carries penetrating liquids such as petroleum fuel. Moreover, any attempt to tighten one pipe end in a coupling tends to loosen the coupling at the opposite end of the pipe section, or other couplings along the same line. The coupling sleeve 10 is formed with two shallow external peripheral grooves 13, one adjacent each end of the sleeve and extending around the whole periphery. The radial depth of each groove may be approximately half the wall thickness and the width may be approximately twice the depth. After the pipe ends have been screwed into the sleeve a modified hand pipe cutter of the type illustrated in Figure 3 is tightened around the coupling sleeve and forcibly turned to cause the rollers 14 to run around the groove 13 thus deforming the sleeve wall as indicated at 15 in Figure 2 and contracting it inwardly to form a rigid joint and fluid-tight seal with the screw threaded end of each pipe. The grooves 13 provide a location for the rollers 14 and allow the walls of the sleeve in this area to be readily compressible. The operation is repeated at the other end of the coupling sleeve and this forms an excellent mechanical and fluid-tight joint which may be capable of resisting internal pressures of up to 400 p.s.i. or greater, i.e., higher than those obtainable using the normal methods of making such couplings.

The parts of the hand tool are identical with a conventional pipe cutter tool except that the normal cutter wheels are replaced by the rollers 14, as illustrated in Figure 4, with rounded peripheries resembling a car tyre instead of the normal sharp edged cutter wheels. The rollers are mounted on the pivot joint between a series of links 16, attached to a hand lever 17, and provided with a tightening clamp 18.

In the modified coupling illustrated in Figure 5, a shoulder 20 is formed at the end of the sleeve 10, instead of the groove 13 as illustrated in Figure 1. The annular projection portion 21 of reduced thickness is deformed inwardly by a modified pipe cutter in the same manner as described previously, so as to grip the screw-threaded end of the pipe 11.

In the further modification illustrated in Figure 6 the coupling sleeve 10 has no internal screw thread but is formed with a

peripheral groove 23 aligned with an annular groove 24 formed near the end of the pipe 25. A line 26 may be marked on the pipe to assist in aligning these grooves 23, 24 before the modified pipe cutter is applied in the same way as described previously to deform the sleeve wall in the region of the groove 23 inwardly into tight sealing engagement with the groove 24.

In the further modification illustrated in Figure 7, the coupling sleeve 10 again has an internal screw thread 31 to fit the external screw thread on the end of the pipe 32. The coupling sleeve also has an annular external groove 33 which is provided with a bevelled flank surface 34 on the side adjacent to the end of the coupling. The final deformation is produced by use of a tool as illustrated previously in Figure 3 but using rollers 35 with bevelled rims 36 instead of the symmetrical tyre-shaped rollers 14 of Figure 4. These bevelled rollers 35 exert a lateral wedging pressure on the flanks of the groove 33 which in some instances facilitates the operation and produces a fluid-type joint with little mechanical effort.

In the further modification illustrated in Figures 8 and 9 the coupling sleeve 40 has an external hand 41 midway along its length, of the same external diameter as the two pipe ends 42 with which the coupling is to be used. Each of these pipe ends has an internal annular socket 43 into which the respective end portion 44 of the coupling sleeve is designed to fit. Each of the end portions 44 of the coupling sleeve is of smaller external diameter than the socket 43 and has an external annular rib or ridge 45 which may have a sharp knife edge or may be rounded. In assembling the joint, two pipe ends 42 are fitted over the ends of the coupling as illustrated in Figure 9 and a tool of the type illustrated in Figure 3 is then applied at the zones 46 to force the thin walled portions 47 of the two pipe ends inwardly against the annular ridges 45 on the coupling. This again provides a rigid fluid-type seal without the need for any organic or other sealing or gasket material and without the need for applying heat, as in a welding process.

#### WHAT I CLAIM IS:

1. A pipe coupling combination comprising two tubular elements in the form of a tubular coupling sleeve and a pipe, the sleeve being dimensioned to be placed in or over the end of the pipe, the wall of the outer of the two tubular elements in the coupled assembly being of reduced thickness in an annular region around its periphery, and constructed of a material softer than that of the inner tubular element, such that the wall in the annular region can be deformed inwardly to provide a positive grip

between the elements

2. A pipe coupling combination according to claim 1 in which the inward deformation of the annular region also provides a seal 5 between the elements.

3. A pipe coupling combination according to claim 1 or 2, in which the annular region is in the form of one or more external annular grooves.

10 4. A pipe coupling combination according to claim 3, in which the or each annular groove is formed at a position adjacent an end of the outer tubular element.

15 5. A pipe coupling combination according to any one of the preceding claims, in which the outer tubular element is internally screw-threaded.

20 6. A pipe coupling combination according to any one of the preceding claims in which the outer tubular element is formed of steel or malleable iron.

25 7. A pipe coupling combination according to any one of the preceding claims, in which the outer tubular element is the tubular sleeve.

30 8. A pipe coupling combination according to any of the preceding claims, in which the inner tubular member has an annular groove on its outer periphery into which the annular region can be deformed inwardly.

35 9. A pipe coupling combination according to any one of claims 1 to 6 in which the inner tubular member includes a projecting annular rib against which the annular region can be deformed inwardly.

10. A pipe coupling combination accord-

ing to any of the preceding claims in which the two tubular elements are formed with co-operating screw-threads.

11. A method of assembling a pipe 40 coupling joint in which one of the tubular elements of the pipe coupling combination according to any of the preceding claims, is placed in or over the end of the other 45 tubular element and the wall of the outer tubular element is deformed inwardly to provide a positive grip between the tubular elements.

12. A method according to claim 11, in which the outer tubular element is deformed 50 by means of a rotary tool provided with a number of spaced rollers, means for pressing the rollers inwardly against the tubular element and means for rotating the rollers 55 bodily around the axis of the tubular element.

13. A pipe coupling combination or a coupled pipe assembly, substantially in any of the forms described with reference to the 60 accompanying drawings.

14. A fluid transfer system such as a fluid supply line, including two tubular elements of a pipe coupling combination according to any of claims 1 to 10, joined to form a 65 coupled assembly.

WYNNE-JONES, LAINÉ & JAMES,  
Chartered Patent Agents,  
33, St. Mary Street,  
Cardiff.  
Agents for the Applicant.

1 542 847 COMPLETE SPECIFICATION  
3 SHEETS This drawing is a reproduction of  
the Original on a reduced scale.  
SHEET 1

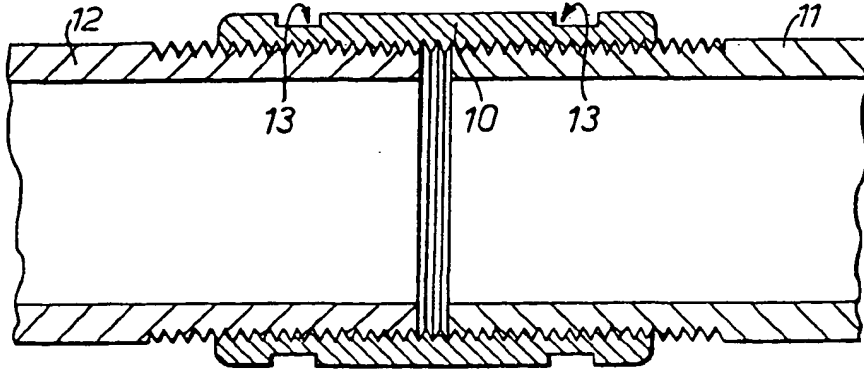

FIG. 1.

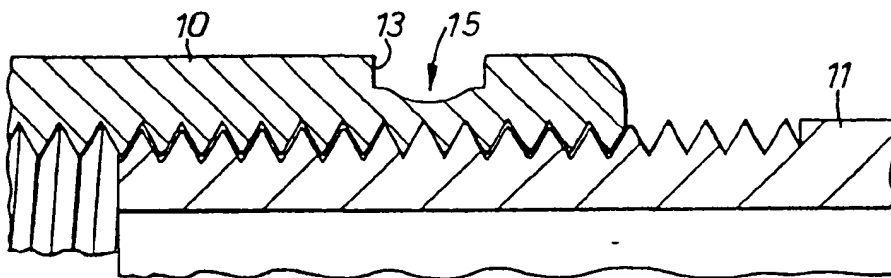

FIG. 2.

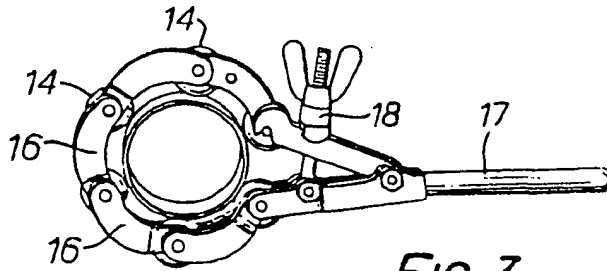

FIG. 3.

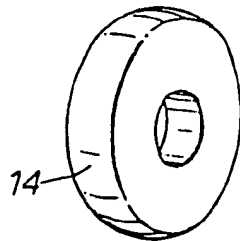

FIG. 4.

1 542 847 COMPLETE SPECIFICATION

3 SHEETS

This drawing is a reproduction of the Original on a reduced scale.  
SHEET 2

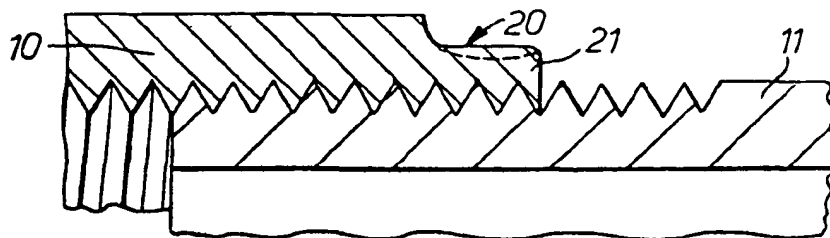

FIG. 5.

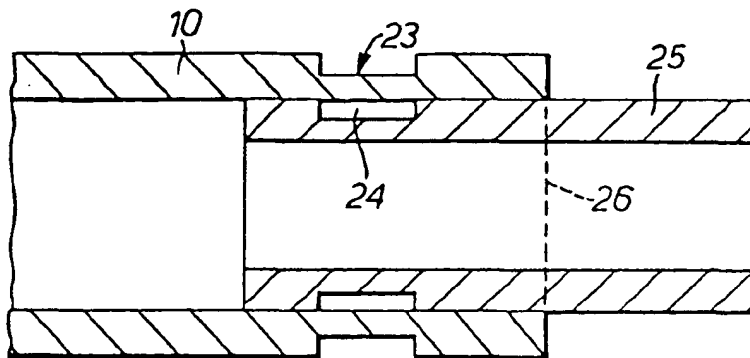

FIG. 6.

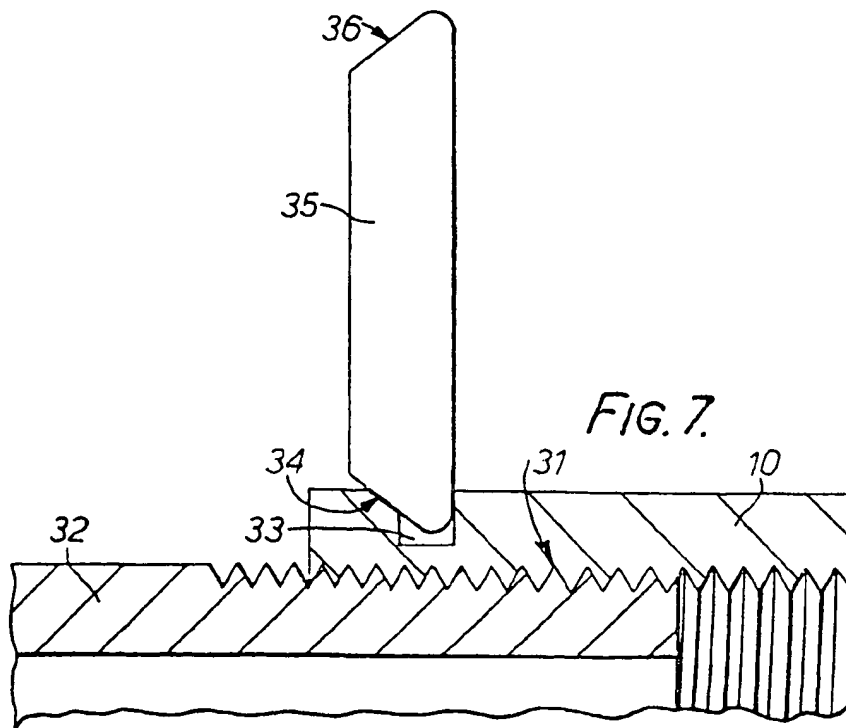

FIG. 7.

1 542 847 COMPLETE SPECIFICATION  
3 SHEETS  
This drawing is a reproduction of  
the Original on a reduced scale.  
SHEET 3

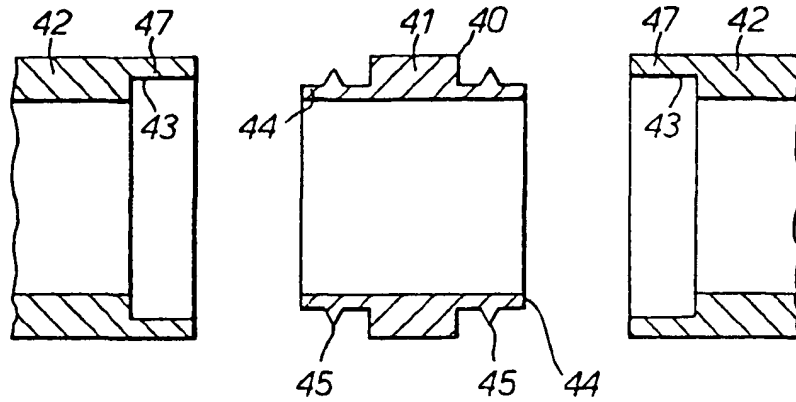

FIG. 8.

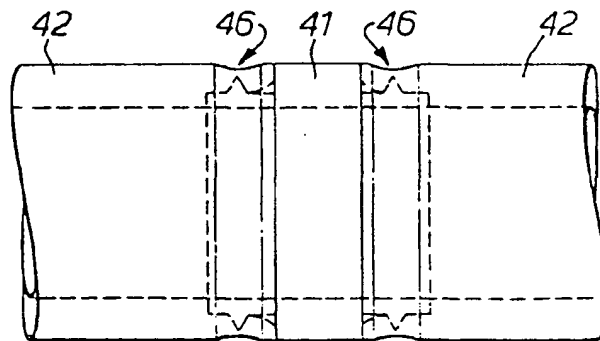

FIG. 9.